

Surname	Centre Number	Candidate Number
First name(s)		2



GCE A LEVEL

1420U30-1



S23-1420U30-1

FRIDAY, 9 JUNE 2023 – MORNING

PHYSICS – A2 unit 3
Oscillations and Nuclei

2 hours 15 minutes

For Examiner's use only			
	Question	Maximum Mark	Mark Awarded
Section A	1.	10	
	2.	15	
	3.	14	
	4.	9	
	5.	10	
	6.	22	
Section B	7.	20	
	Total	100	

ADDITIONAL MATERIALS

In addition to this examination paper, you will require a calculator and a **Data Booklet**.

INSTRUCTIONS TO CANDIDATES

Use black ink or black ball-point pen. Do not use gel pen or correction fluid.

You may use a pencil for graphs and diagrams only.

Write your name, centre number and candidate number in the spaces at the top of this page.

Answer **all** questions.

Write your answers in the spaces provided in this booklet. If you run out of space, use the additional page(s) at the back of the booklet, taking care to number the question(s) correctly.

INFORMATION FOR CANDIDATES

This paper is in 2 sections, **A** and **B**.

Section A: 80 marks. Answer **all** questions. You are advised to spend about 1 hour 35 minutes on this section.

Section B: 20 marks. Comprehension. You are advised to spend about 40 minutes on this section.

The number of marks is given in brackets at the end of each question or part-question.

The assessment of the quality of extended response (QER) will take place in question **3(d)**.



JUN231420U30101

SECTION AAnswer **all** questions.

1. The first law of thermodynamics may be written as:

$$\Delta U = Q - W$$

- (a) State the meaning of: [3]

 ΔU Q W

- (b) A closed cylinder fitted with a leak-proof piston as one end contains 0.060 mol of an ideal monatomic gas. The volume of the system is
- $1.4 \times 10^{-3} \text{ m}^3$
- and the pressure of the gas is 100 kPa. Determine the temperature of the gas. [2]

.....

.....

.....

- (c) The gas is heated and expands at constant pressure to a volume of
- $2.0 \times 10^{-3} \text{ m}^3$
- . Determine:

- (i) the work done by the gas, [2]

.....

.....

.....

- (ii) the increase in the internal energy of the gas, [2]

.....

.....

.....

- (iii) the heat transferred to the gas. [1]

.....

.....



2. (a) Explain what is meant by centripetal force and state its direction. [2]

.....

.....

.....

- (b) A small sphere of mass 30 g at the end of a light string rotates in a horizontal circle of radius 0.80 m and completes 10 revolutions in 15 s.

- (i) Show that the speed of the sphere is 3.35 ms^{-1} . [2]

.....

.....

.....

- (ii) Calculate the centripetal force on the sphere. [2]

.....

.....

.....



- (c) The sphere now rotates in a **vertical** circle of the same radius, from a point that is 1.20 m above the ground. The speed at the top of the circle is 3.35 m s^{-1} .

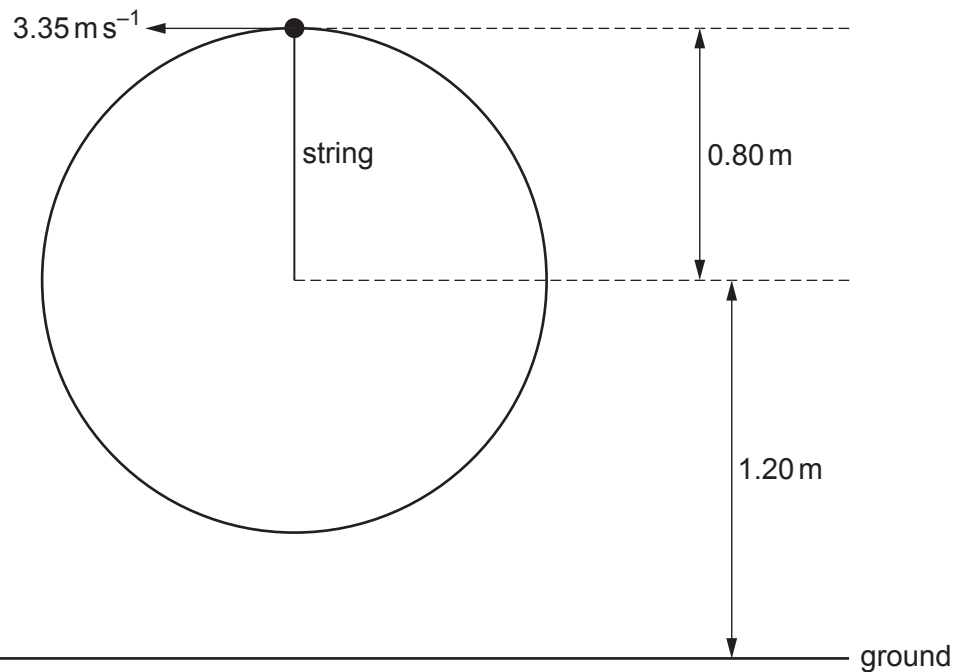

Calculate the tension in the string at the **top of the circle**.

[2]

.....

.....

.....

- (d) (i) Calculate the speed of the sphere when it reaches the **bottom of the circle**. [3]

.....

.....

.....

.....

.....



Examiner
only

(ii) A student claims that if the string breaks when the sphere is at the **top of the circle** it will reach the ground at a horizontal distance of approximately 2 m away from the point of release. Investigate if her claim is correct, justifying your answer. [4]

.....

.....

.....

.....

.....

.....

.....

.....

15

1420U301
05



Examiner
only

3. (a) State what is meant by alpha emission. [2]

.....

.....

.....

(b) Americium-241 has a half-life of 432 years. Determine the percentage **decrease** in the activity of the element after 30 years. [4]

.....

.....

.....

.....

.....

.....

.....

(c) A builder is asked to install a smoke detector. He researches smoke detectors and finds that the radioactive source in the detector emits alpha particles. He decides that it is too dangerous to install the detector. Discuss whether or not he has used science well in his decision making. [2]

.....

.....

.....

.....



(d) Describe how alpha, beta and gamma radiation can be distinguished:

- by using different absorbers
- by using an electric field **or** a magnetic field.

[6 QER]

A series of horizontal dotted lines providing space for the candidate's answer.

1420U301
07

14



4. (a) Explain what is meant by specific heat capacity. [2]

.....

.....

.....

(b) A volume of $1.2 \times 10^{-3} \text{ m}^3$ of water is heated in a 3 kW kettle.

Specific heat capacity of water (and tea) = $4200 \text{ J kg}^{-1} \text{ K}^{-1}$

Specific heat capacity of milk = $3900 \text{ J kg}^{-1} \text{ K}^{-1}$

Density of water = $1.00 \times 10^3 \text{ kg m}^{-3}$

Density of milk = $1.03 \times 10^3 \text{ kg m}^{-3}$

(i) Determine the time it takes to increase the temperature of the water from 18°C to 100°C . [3]

.....

.....

.....

.....

.....

(ii) A volume of $0.25 \times 10^{-3} \text{ m}^3$ of the heated water is used to make tea and this is poured into a thermos flask. The temperature of the tea when in the flask is 95°C . Milk at 5°C is then poured into the flask. Determine whether $3.6 \times 10^{-5} \text{ m}^3$ of milk will lower the temperature of the mixture to the required temperature of 84°C . [4]

.....

.....

.....

.....

.....

.....

.....

.....

.....

.....



5. (a) Nuclear energy can be released by fusion and fission. Discuss these processes in terms of energy and the stability of the nuclei. Use the graph of the binding energy per nucleon in your answer. [4]

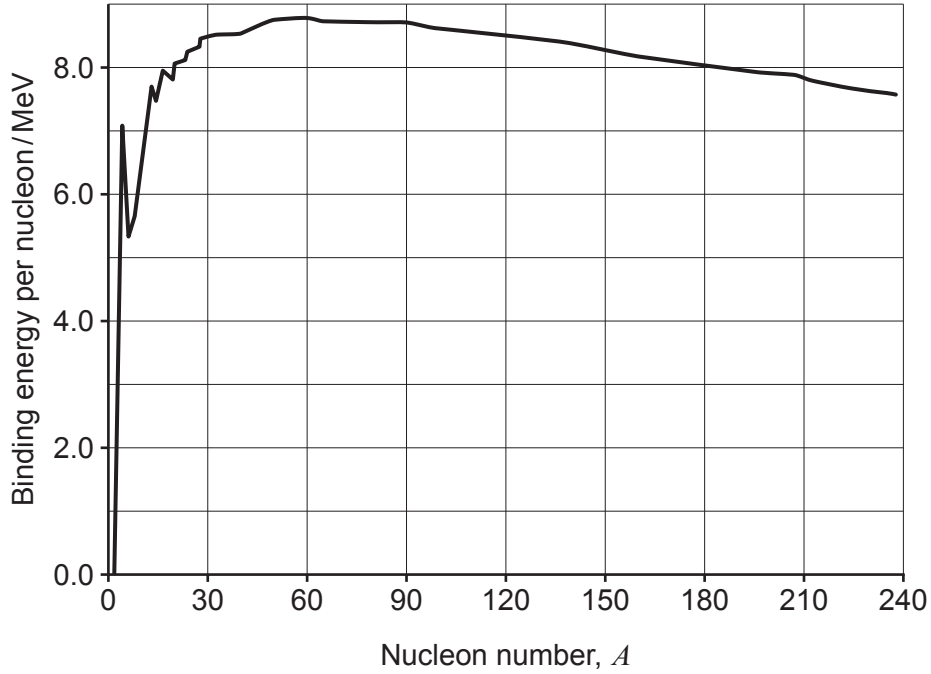

.....

.....

.....

.....

.....

.....

.....

.....



- (b) One of the many possible fission reactions of uranium-235 is:

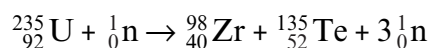

The masses are:

${}_{92}^{235}\text{U}$: 235.04393 u; ${}_{40}^{98}\text{Zr}$: 97.91273 u; ${}_{52}^{135}\text{Te}$: 134.91645 u, ${}_0^1\text{n}$: 1.00866 u
and 1 u = 931 MeV.

- (i) State what is meant by the Avogadro constant. [1]

.....
.....

- (ii) Calculate the energy released by the fission of 0.0010 kg of uranium-235 in this reaction. Give your answer in J. [5]

.....
.....
.....
.....
.....
.....
.....
.....
.....
.....
.....
.....

--

10



6. A student says that a simple pendulum oscillates with simple harmonic motion with a period, T , of:

$$T = 2\pi\sqrt{\frac{l}{g}}$$

where l is the length of the pendulum and g is the acceleration due to gravity.

- (a) Describe what is meant by a simple pendulum.

[1]

.....

.....

- (b) State what is meant by simple harmonic motion.

[2]

.....

.....

.....

- (c) The student sets up two experimental systems to investigate simple harmonic motion. System A is a pendulum of length 0.10 m oscillating with an amplitude of 0.05 m. System B is a pendulum of length 0.50 m oscillating with an amplitude of 0.04 m. Give two reasons why system B is better than system A to investigate simple harmonic motion.

[2]

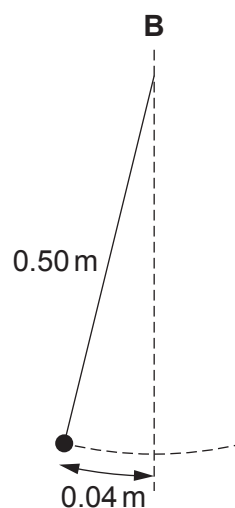
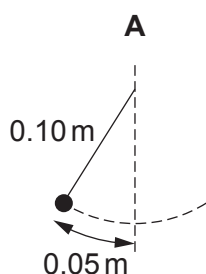

Diagrams not to scale.

.....

.....

.....



- (d) Measurements for an oscillating simple pendulum are given in the table below, where l is the length of the pendulum and T_{20} is the time taken for 20 oscillations. For each value of l four values of T_{20} are measured.

l/m	$\sqrt{l}/m^{1/2}$	T_{20}/s	Mean T_{20}/s	Uncertainty T_{20}/s
0.250	0.50	19, 21, 22, 20	21	2
0.500	0.71	26, 29, 26, 29	28	2
0.750	35, 34, 33, 36
1.000	42, 39, 40, 41
1.250	45, 42, 44, 45
1.500	48, 50, 49, 52

- (i) **Complete the table** by determining \sqrt{l} , the mean time for 20 oscillations, T_{20} and the uncertainty in T_{20} . Values have been inserted for the first two lengths. [3]
- (ii) Plot mean T_{20} against \sqrt{l} on the grid below. Include error bars on the T_{20} axis only. Draw a line of maximum gradient and a line of minimum gradient. [4]

Mean T_{20}/s

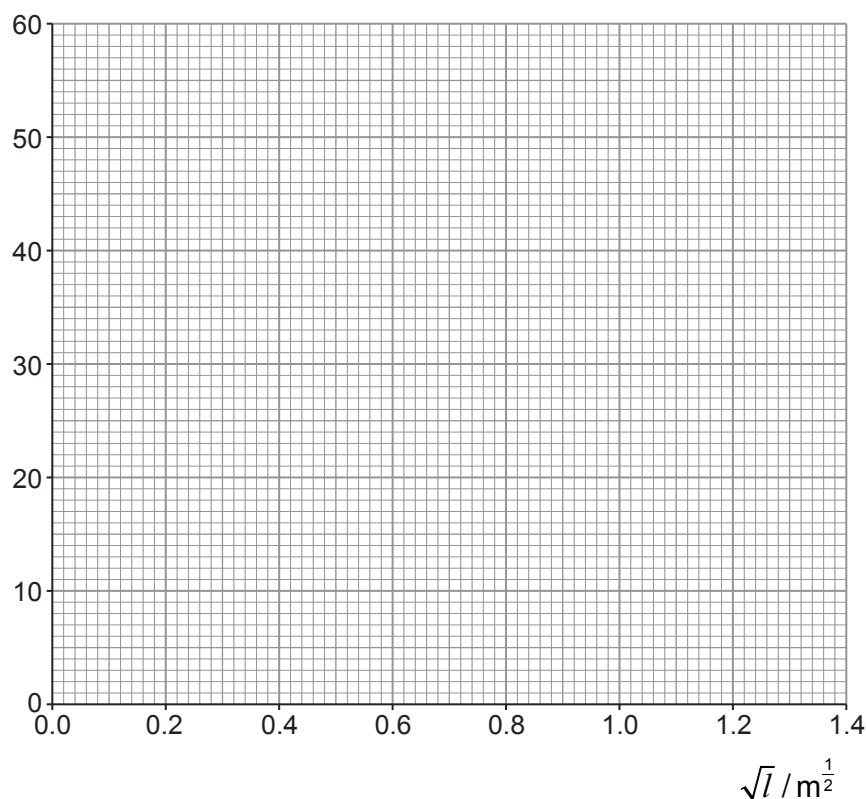

(iii) Justify why error bars for \sqrt{t} are not plotted on the graph. [2]

.....

.....

.....

(iv) Use the maximum and minimum gradients to determine a mean value for the acceleration due to gravity, g , and its **percentage** uncertainty. [5]

.....

.....

.....

.....

.....

.....

.....

.....

.....

.....

(e) Another student says that the gradient of the graph would be approximately twice as large if the experiment was carried out on the Moon, where the acceleration is approximately $0.2g$. Investigate if this statement is correct, justifying your answer. [3]

.....

.....

.....

.....

.....



SECTION B

Answer **all** questions.

7. Read through the following article carefully.

Paragraph

A summary of binary stars

First of all, we call two stars orbiting their common centre of mass a “binary star”. Binary stars fall into 5 different classes, categorised by the detection method: 1

1. Visual binaries
2. Spectroscopic binaries
3. Eclipsing binaries
4. Astrometric binaries
5. Non-eclipsing binaries that can be detected using photometry.

Visual binaries

These do what it says on the tin – the angular separation of the stars is great enough that both stars can be seen as separate objects through a telescope. There is a simple relationship between the minimum angular separation θ (in radians), the diameter, d , of the telescope and the wavelength, λ , of the radiation used. 2

$$\theta = 1.22 \frac{\lambda}{d} \quad \text{Equation 1}$$

This equation means that a nearby binary star that is around 200 light years (l-y) away will only be visible as two stars with a $d = 8.0\text{ m}$ telescope if the two stars are separated by at least the Earth-Sun distance of $1.5 \times 10^{11}\text{ m}$ (see Figure 1). 3

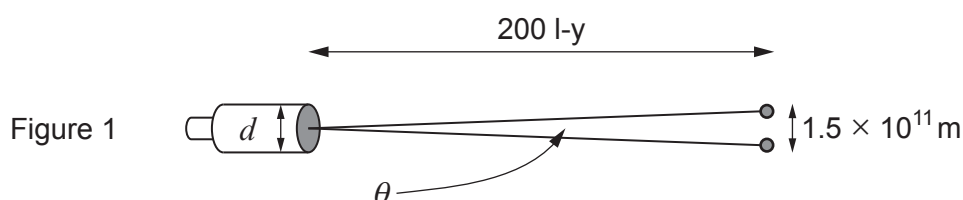

Perhaps the most famous of visual binary stars is the brightest star in the night sky – Sirius. Sirius is not, in fact, a single star but a binary consisting of Sirius A and Sirius B that orbit each other with a period of around 50 years. Sirius A is a main sequence star which has roughly 2 times the mass of the Sun, 1.7 times the Sun’s temperature and 25 times its luminosity. Sirius B is a white dwarf with a similar mass to our Sun, a surface temperature 4.3 times greater than our Sun but a luminosity 18 times less than our Sun. 4

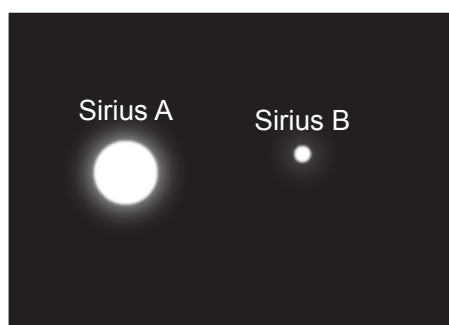

Figure 2



Spectroscopic binaries

These are binaries where the stars cannot be viewed separately but the existence of the two stars can be inferred from the variation of the Doppler shifted light from the system. Both stars will orbit their mutual centre of mass and hence their Doppler shifts will vary periodically during their orbits. This theory is the same as that used to discover exoplanets from the wobble of their parent star. 5

Eclipsing binaries

These happen when the line of sight of the observer is in the plane of the orbit of the two stars. When this happens, one star can pass directly in front of the other leading to a drop in the intensity of light entering the observer's telescope. An idealised graph of intensity against time is shown in Figure 3. 6

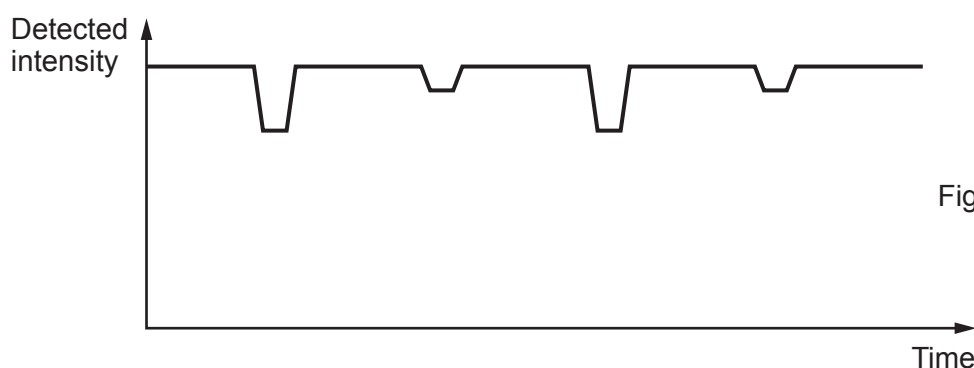

Figure 3

In general, there are two eclipses for each orbit. The larger of the two dips in intensity occurs when the hotter of the two stars is blocked by the colder star. 7

Astrometric binaries

These are binary systems where only one star is visible and that star can be seen moving in an orbit around something which is invisible. These are different from spectroscopic binaries because the visible star can actually be seen to move rather than inferring its motion from the variation of the Doppler shift. Stars orbiting neutron stars have been observed by this method but the ultimate goal of this technique would be to observe a star orbiting a black hole. 8

Non-eclipsing binaries that can be detected using photometry

This simply means detecting binaries by measuring light intensity but not via the eclipsing method described earlier. It turns out that there are three different techniques of finding binaries within this class of binary. First, an increased light intensity can be detected periodically from the binary system – this is caused by light being reflected from one star, off the other and into the Earth's telescope. Second, one star can exert such a strong gravitational pull on the other that it becomes deformed – this leads to a periodic fluctuation in the light intensity detected. Third, is an effect sometimes known as Doppler beaming – a star moving towards an observer will lead to an increased number of photons detected per second (as well as a decrease in the wavelength). 9

These 5 different classes of binary stars can provide an enormous amount of valuable data regarding stellar orbits and masses but they can also allow measurement of galactic distances and even give insights into black holes and supernovae. 10



Examiner
only

Answer the following questions in your own words. Direct quotes from the original article will not be awarded marks.

- (a) A light year is 9.46×10^{15} m. Use equation 1 and a wavelength of 500 nm to show that the author's claim about an 8 m telescope viewing the binary star mentioned in paragraph 3 and Figure 1 is correct. [4]

.....

.....

.....

.....

.....

.....

.....

- (b) (i) Show that the distance between Sirius A and Sirius B is approximately 3×10^{12} m (see paragraph 4). [Mass of the Sun is 2×10^{30} kg.] [2]

.....

.....

.....

.....

.....

- (ii) Show that the centre of mass of the Sirius binary system is located approximately 1×10^{12} m from Sirius A. [2]

.....

.....

.....



Examiner only

(iii) Use data in paragraph 4 and Stefan’s law to calculate the ratio of the radii of Sirius A and Sirius B: [4]

$$\frac{R_{\text{Sirius A}}}{R_{\text{Sirius B}}}$$

.....

.....

.....

.....

.....

.....

.....

(c) (i) Evaluate whether the variation of light intensity shown in Figure 3 is consistent with an eclipsing binary system (see paragraph 6). [3]

.....

.....

.....

.....

.....

(ii) Use Stefan’s law to explain why the “larger of the two dips in intensity occurs when the hotter of the two stars is blocked by the colder star” (see paragraphs 6 and 7 and Figure 3). [2]

.....

.....

.....



Examiner
only

(d) Explain why a star orbiting a much more massive black hole is an astrometric binary (see paragraph 8). [1]

.....

.....

.....

(e) One of the three methods for detecting non-eclipsing binaries that can be detected by photometry, suggests that stars do not behave as ideal black bodies. Explain which **one** of the three methods relies on stars not behaving as black bodies (see paragraph 9). [2]

.....

.....

.....

20

END OF PAPER



Question number	Additional page, if required. Write the question number(s) in the left-hand margin.

Examiner
only

BLANK PAGE

**PLEASE DO NOT WRITE
ON THIS PAGE**

